



BELT SCREEN

THE BEST SOLUTION,
IF YOU THINK ABOUT
CLEAN WATER



CP – a reliable solution for coarse and fine wastewater treatment

IN-EKO TEAM s.r.o. has specialized in the manufacture of wastewater treatment units since 1995. We used all our knowledge and

experience in coarse and fine wastewater pretreatment when developing the belt screen. The IN-EKO TEAM belt screen has been developed

to provide the most effective protection of downstream technology and particulate removal.

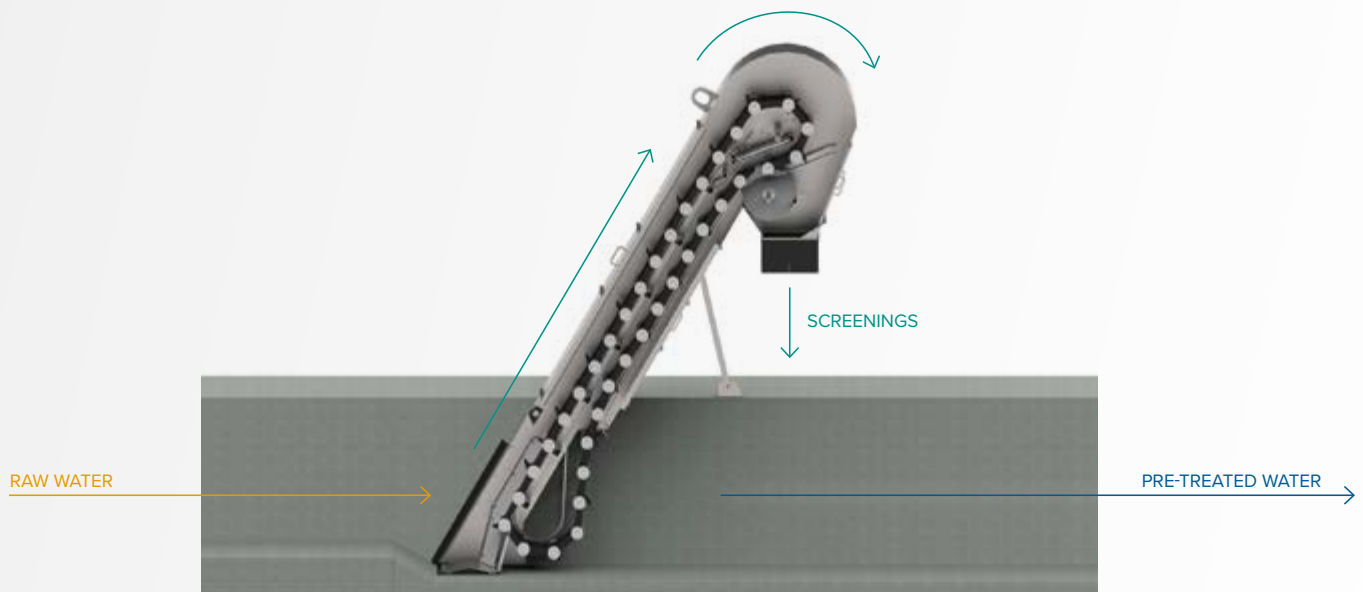

Design and properties of the Belt Screen

- We use only quality materials to ensure the highest standards in wastewater treatment technology
- The endless belt is tailor-made to the type of application
- Automatic and adjustable spraying ensures perfect cleaning of the endless belt and rinsing of the screenings
- A belt screen cover to eliminate odours and increase the hygiene standard of the WWTP is always included with the device
- Sophisticated sealing of the space between the endless belt and the bottom of the channel
- A reliable system monitors the tension of the endless belt, preventing overloading and device damage

How does it work?

Untreated water flows by gravity towards the screen belt, which traps solids from the water larger than the installed openings. These screenings are subsequently carried above the water

surface to the head of the belt screen, where they fall into a hopper. The screen bars are cleaned by a rotating brush and optionally rinsed. The belt screen cleaning is initiated together with the belt

drive. Belt operation can be controlled by a timer or the water-level probe supplied as standard.

The screen discharge hopper is usually connected to a screw conveyor or a screw press.

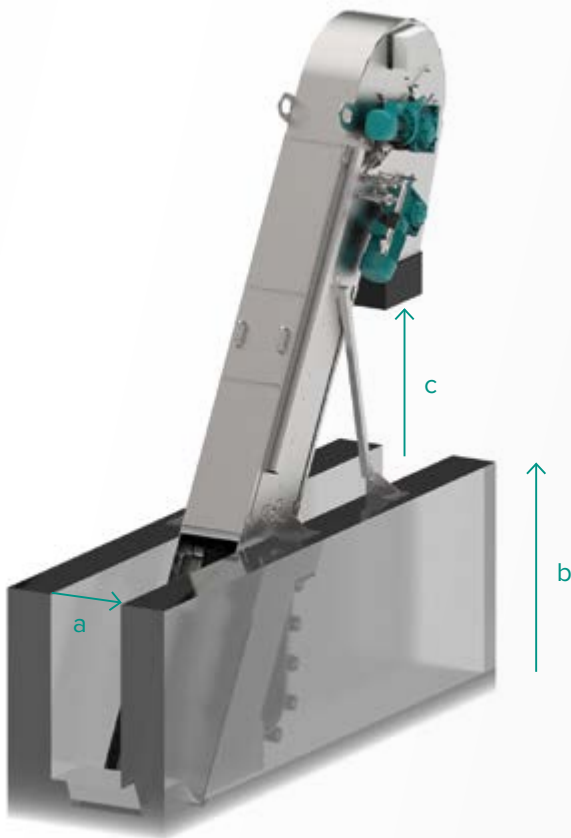

← channel width
(a) = 400 – 1600 mm

channel depth
(b) = 600 – 10 000 mm

height of the outlet hopper
(c) = 600 – 1500 mm



Design

The belt screens are divided into coarse (10–100 mm) and fine (1–10 mm) according to the size of the openings in each screen. Depending on the belt screen space and capacity, we choose a 60° or 75° inclination or a completely customized inclination.



Endless belt – openings

Optional accessories

- Sealing adapter for channels wider than the screen
- Integrated press - dewatering and compaction of screenings
- Insulation and heating
- Tilting mechanism
- Tension meter
- Height-adjustable consoles
- Left/right orientation
- Stainless steel conveying lamellas

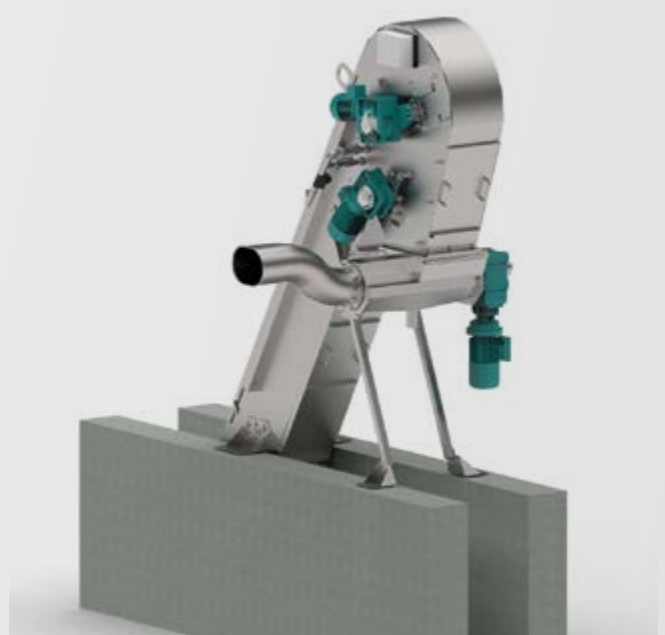

Belt screen with integrated press

Advantages of the Belt Screen

- Made exclusively of high quality stainless steel and high quality plastic components with excellent mechanical wear resistance
- Low operating cost and reliable operation
- Proven structural design guarantees a long life span
- Equipped with an overload protection system for the endless belt drive

Applications

- Wastewater treatment plants
- Meat industry
- Food industry
- Leather industry
- Chemical industry
- Treatment plants
- Others

Applications



WWTP, Mojmírovce, Slovakia, 500_CP_3500_Z



Pumping station, Sazovice, Czech Republic, 1000_CP_3250_Z



WWTP, Stupava, Czech Republic, 800_CP_1050 + LS_2400

✓ The right choice

When choosing the optimum belt screen, it is essential to consider the channel dimensions and the maximum device flow rate. Another important parameter is the screen belt opening size, which must correspond to the size of the solids to be removed from the water.

Optimal belt screen operation can be managed using a PLC or other computerized system.

The belt screen can be delivered for a concrete channel installation or in a steel tank depending on the specific situation.

For outdoor installations, we offer an insulated version with optional heating and waterproofing for the electrical components.

+ Benefits for customers

- A great solution also for industrial applications
- Tailor-made device manufacturing
- Low operating cost
- Reliable and foolproof operation
- Long life span
- Timer or level switch control for the endless belt to minimize wear and power consumption
- The belt screen can be put into operation immediately after its installation

More information about our belt screen and other units in our complete product line of wastewater pretreatment and microfiltration can be found at www.in-eko.com.

You can contact us by email, phone or in person.



IN-EKO TEAM s.r.o. has specialized in the production of filtration and wastewater treatment units since 1995.