



CONTAINERIZED MODULAR RECYCLING SYSTEM

PHOSPHORUS REDUCTION
MICROPOLLUTANTS REMOVAL
WATER RE-USE

Advanced tertiary and
quaternary treatment
solution

IN-EKO

NEWWATER
GROUP

REPHOS-COMORES

Intelligent tertiary water treatment with P reduction

The highly efficient and innovative **REPHOS-COMORES** technology treats the effluent and **reduces the phosphorus** concentration through tertiary coagulation with microscreen filtration. This technology stably

reduces the phosphorus concentration **down to 0.1 mg/l** and effectively minimizing the potential for algae and cyanobacteria growth. Additionally, it serves as an **effective pre-treatment** before subsequent stages **of**

potential **quaternary water treatment**. The REPHOS-COMORES technology can be implemented at full WWTP capacity, available in built or container form (2,000-10,000 PE).

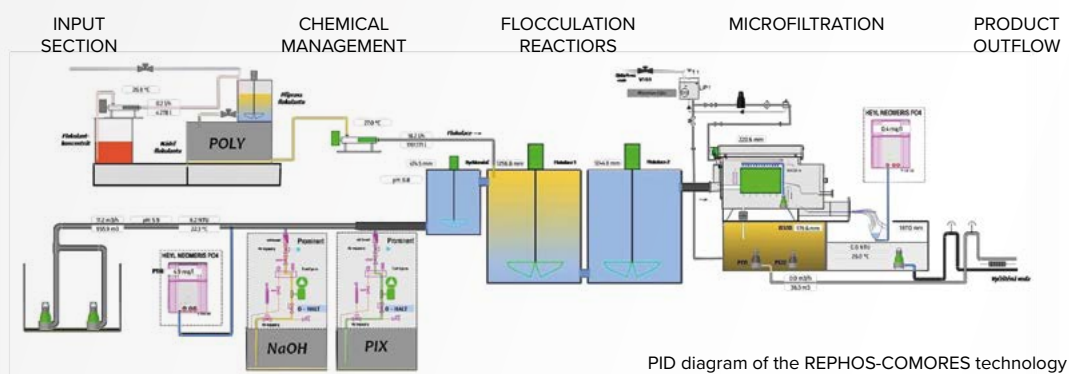

PID diagram of the REPHOS-COMORES technology

How does the REPHOS-COMORES work?

The technology is **based on the precise dosing of reagents** into the influent water **and a controlled flocculation process in a cascade of vertically mixed reactors**. Precise dosing is achieved by measuring the instantaneous flow rate using a flow meter and simultaneously monitoring the input concentration of $\text{PO}_4\text{-P}$

using an analyzer. Coagulant based on Fe or Al is dosed, along with a sodium hydroxide solution if necessary, and additionally, a solution of polymeric flocculant is used in the technology. **Separation of floc particles from phosphorus precipitation occurs on a Microscreen filter** with 10 μm or 20 μm filter cloth.

Advantages of the REPHOS-COMORES

- **Ensuring stable outflow parameters** for water treatment in the required quality for further use (phosphorus reduction down to 0.1 mg/l, reduction of algae and cyanobacteria)
- **Low power consumption** – 0.35–0.55 kW/m³ of treated water (including pumped inflow and outflow to the technology)
- **Online monitoring** of phosphate concentration inflow/outflow and automatic control of precipitant doses by $\text{PO}_4\text{-P}$ analyzer = **reduction of OPEX of the whole technology**
- **Precise and automatic dosing** (concentration-influx proportional dosing)
- **Autonomous control system with artificial intelligence and reliable operation**
- Customer communication protocols
- Automatic backwashing system of a Microscreen filter
- Sludge without residual chemicals

MINT-COMORES

Advanced quaternary water treatment utilizing artificial intelligence

The **MINT-COMORES** treatment plant enables the production of **high-quality and safe drinking water free from MICROPOLLUTANTS**, using either municipal wastewater

treatment plant (WWTP) effluent or a wide range of surface and groundwater sources. The produced water complies with **World Health Organization requirements**

and national standards in terms of its parameters, including quality and composition.



Direct nanofiltration with hollow fiber membranes (DNF)

POTABLE WATER from various surface and underground sources

MICROPOLLUTANTS, MICROPLASTICS REMOVAL and **DISINFECTION** in one process step

MOBILITY, quick installation and easy operation

AUTONOMOUS OPERATION guided by artificial intelligence

How does the MINT-COMORES work?

The MINT-COMORES treatment plant signals the entrance of a new and highly innovative solution to the water treatment market. A new advanced membrane process – **DIRECT NANOFILTRATION** with hollow fiber membranes is integrated with feed pre-treatment and final product polishing. Comprehensive monitoring

of the whole plant with remote access and a sophisticated control system utilizing artificial intelligence are also included. This containerized water treatment plant is a fully assembled functional technology which allows easy installation and Plug&Play commissioning.

Advantages of the MINT-COMORES

- Replaces all other used combinations of conventional membrane separation processes: ultrafiltration (UF), nanofiltration (NF) and reverse osmosis (RO) with **one single process step: DIRECT NANOFILTRATION (DNF)**
- **Separation and removal of micropollutants** (more than 80 %) ensures effective quaternary water treatment
- **High recovery rate** (up to 85 %) to produce micropollutant-free potable water
- Lower transmembrane pressure (1-4 bar) and energy consumption (up to 1 kWh/m³) allows **low OPEX** (less than 0.4 €/m³ of produced water)
- **Longer membrane lifetime** thanks to automatic membrane cleaning
- **Autonomous control system** with artificial intelligence and **remote access** allows unattended and reliable operation

COMORES – comprehensive modular recycling system for tertiary and quaternary waste water treatment

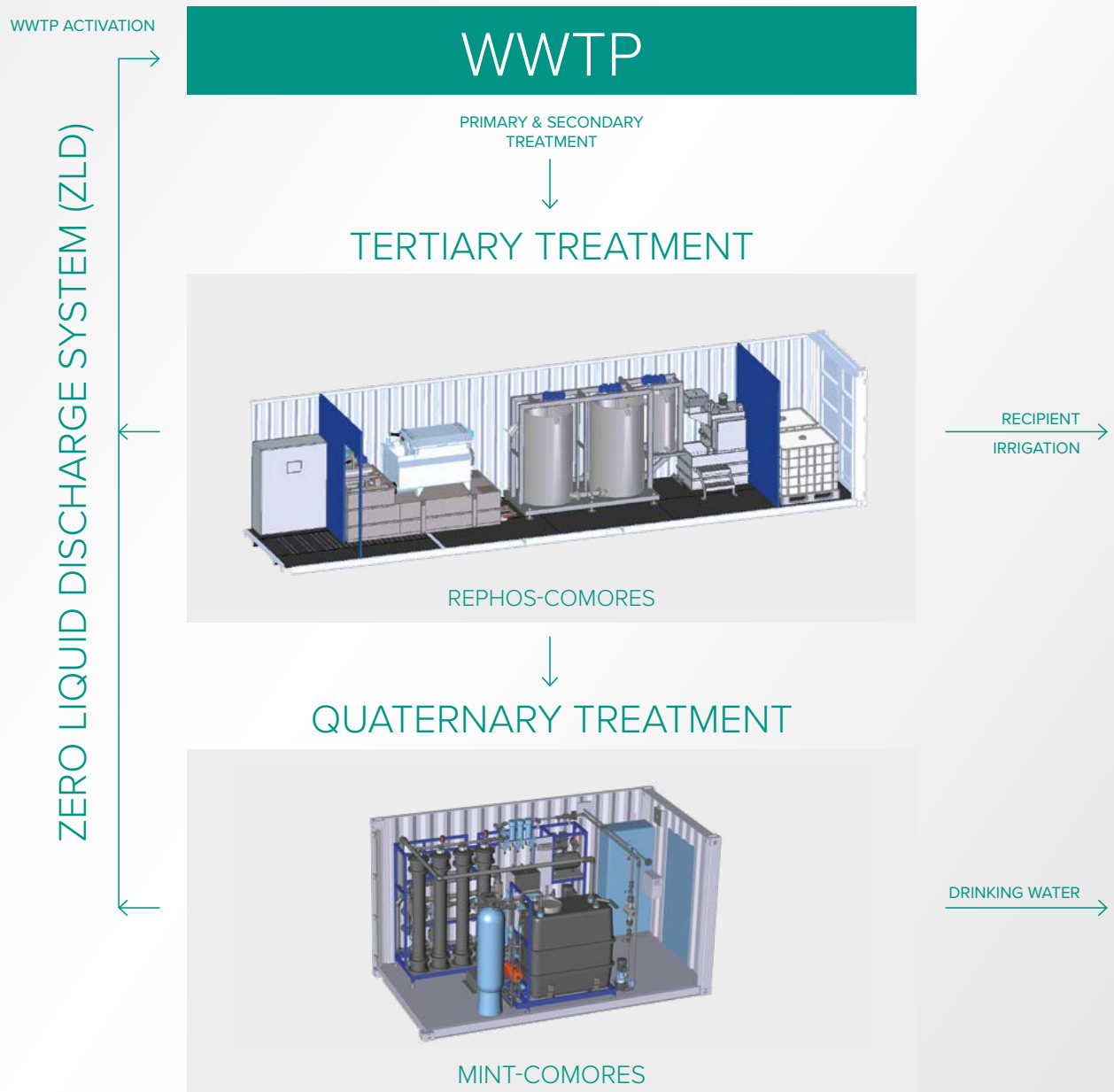

You can contact us by phone, email or in person.



IN-EKO TEAM s.r.o. has specialized in the production of filtration and wastewater treatment units since 1995.



New Water Group s.r.o. has specialized in Membrane Intelligence Technologies – MINT since 2019.