



# PULP & PAPER INDUSTRY

LEADING  
WASTEWATER  
SOLUTIONS

ALL  
FOR  
WATER

**IN-EKO**<sup>®</sup>  
TEAM

# Microscreen filters: ideal solution for pulp & paper industry

Nowdays is more and more important to treat wastewater and return the treated water back to the process, especially

in the pulp and paper industry, where is a need to have high amounts of fresh water for the production process.

You have to also deal with the high environmental impact and big costs. IN-EKO TEAM can help you with that!

## Microscreen drum filter

Very first product done by IN-EKO TEAM was a **Microscreen Drum filter**, which can be used in **Pulp and Paper industry**, Cooling water in various industries, Inlet process water and irrigation systems, Fish farms, Koi ponds, Pretreatment before UV, Pretreatment of potable water, Food processing and in many other areas.



## Technical specifications

- Filter cloth is available with mesh opening sizes ranging from 20  $\mu\text{m}$
- Filter capacity up to 250 l/s
- Higher quality of effluent water
- Recovery of valuable materials back to the process helps to save initial investment costs
- Low maintenance costs
- Low power consumption
- Exceptionally fast and easy replacement of CLI-CLO cartridges
- Fully automated operation
- Small footprint requirements
- High resistance to wear and damage
- Fast return of investment costs

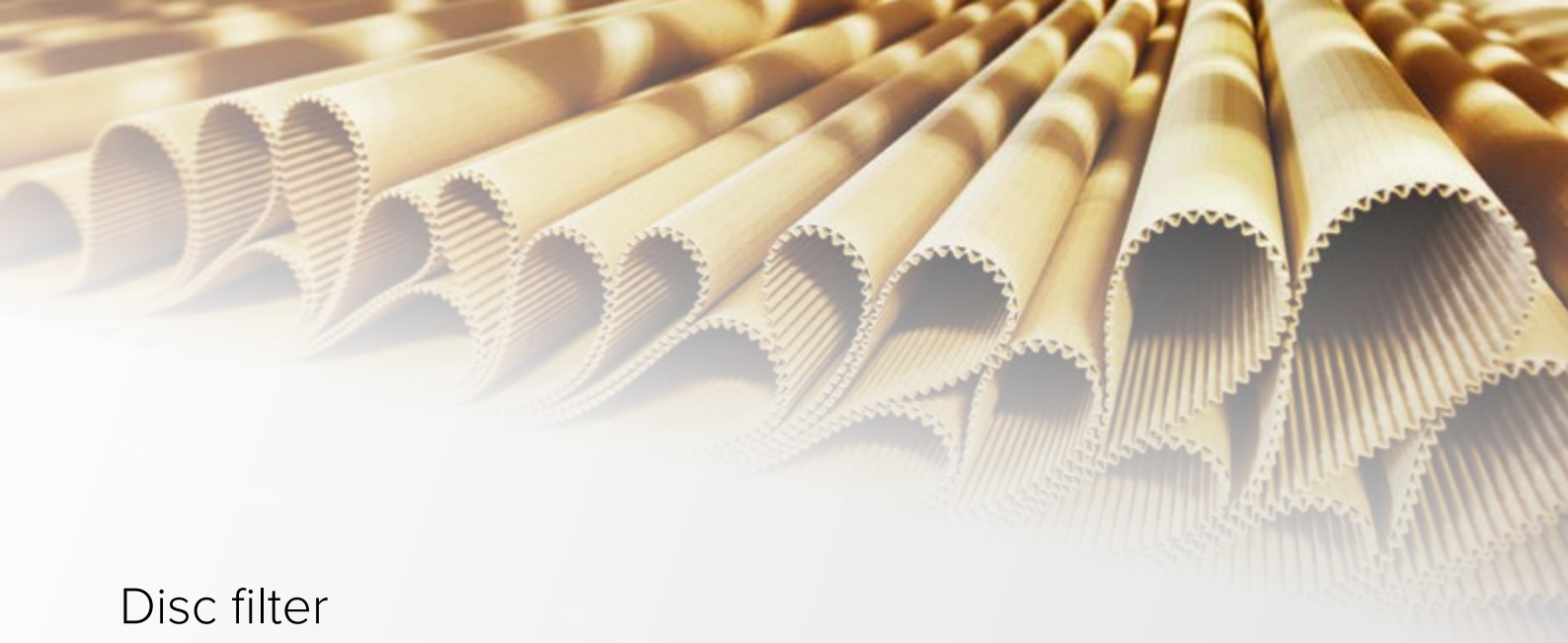

## Disc filter

Our **Disc filters** can be used in the same application as the Microscreen Drum filters. Their main advantage compared to Drum filters is their bigger filter capacity and also the filtration is possible from 5  $\mu\text{m}$ .

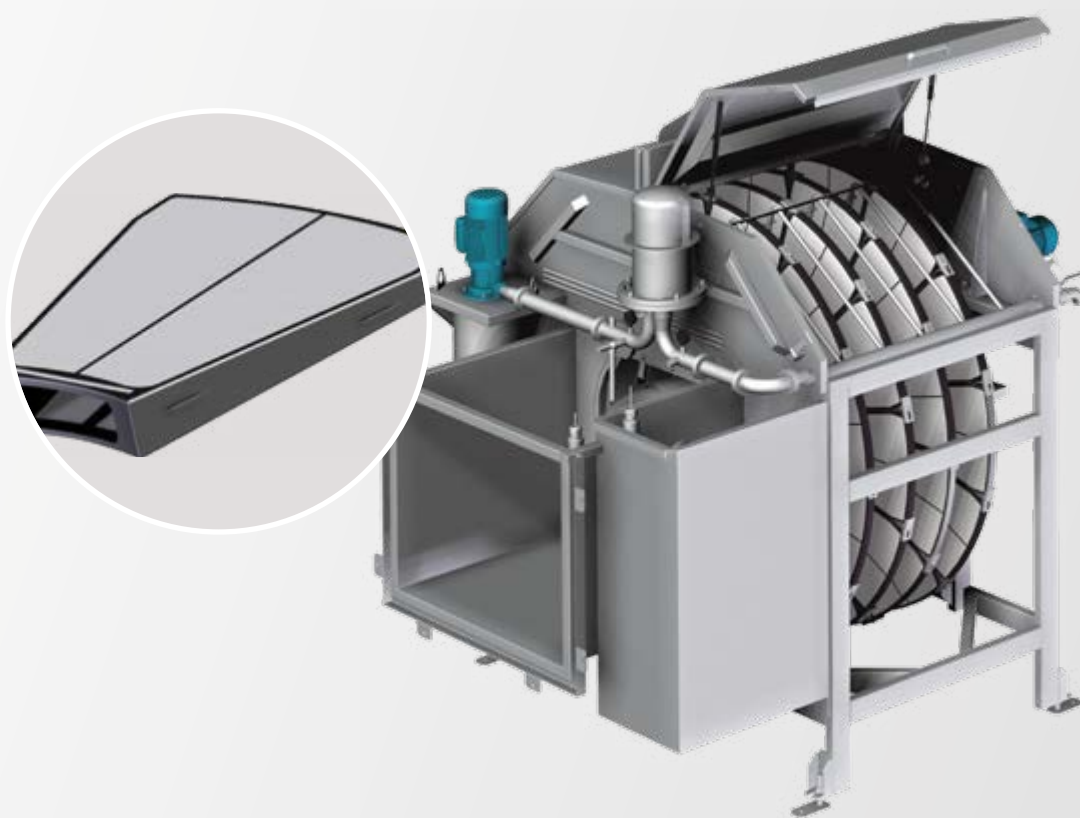

## Technical specifications

- Filter cloth is available with mesh opening sizes ranging from 5  $\mu\text{m}$
- Filter capacity up to 1000 l/s
- Higher quality of effluent water
- Recovery of valuable materials back to the process helps to save initial investment costs
- Low maintenance costs
- Low power consumption
- Large filtration area in small space
- Exceptionally fast and easy replacement of filter cassettes
- Fully automated operation
- High resistance to wear and damage
- Fast return of investment costs

# References



## Metsä tissue – düren, D

- Microscreen Drum filter
- type 4FBO + 5FBO
- 2 pcs + 1 pc
- Max. capacity: 28,5 l/s
- Filtration cloth: 30  $\mu$ m + 20  $\mu$ m
- Loading of solids: 80 mg/l, after filtration 25 + 10 mg/l
- Installation after the Vacuum disc filtration as a two stage filtration. Filtered water is used back on washing nozzles and for vacuum pumps.



## Metsä tissue – krapkowice, PL

- Microscreen Drum filter
- type 10\_BMF\_20\_O
- 2 pcs
- Max. capacity: 28 l/s
- Filtration cloth: 40  $\mu$ m
- Loading of solids: 100–220 mg/l, after filtration 20 mg/l
- Installation after the DAF. Filtered water is used back on washing nozzles of paper machine.

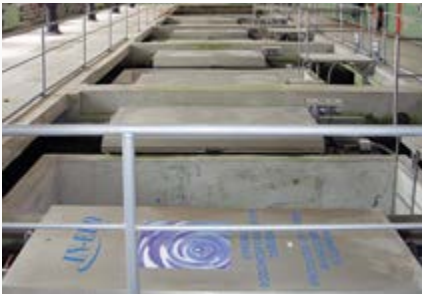

## Smurfit kappa slovakia, SK

- Microscreen Drum filter
- type 10\_BMF\_20\_BK2
- 10 pcs
- Max. capacity: 971 l/s
- Filtration cloth: 90  $\mu$ m
- Loading of solids: 30 mg/l, after filtration 15 mg/l
- The devices are installed as a part of a group of ten filters designed to filter water pumped from the Danube river as a source of process water for the paper mill.

More information on our Disc filters, Microscreen drum filters and other units from our complete product line of pretreatment and filtration of waste water can be found at [www.in-eko.com](http://www.in-eko.com).

If you have any queries, please contact us  
by email, phone or in person.